

Sagittal Bone Saw With Orbital Blade Motion for Improved Cutting Efficiency

Thomas P. James¹

e-mail: thomas.james@tufts.edu

Matthew P. Kelly

Timothy B. Lannin

John J. Pearlman

Anil Saigal

Laboratory for Biomechanical Studies,
Department of Mechanical Engineering,
Tufts University,
200 College Avenue,
Medford, MA 02155

Sagittal bone saws are used by orthopedic surgeons for resection of bone; for example in total joint arthroplasty of the hip and knee. In order to prevent damage to surrounding tissue, sagittal saw blades typically oscillate through a small angle, resulting in reduced cutting rates due to short stroke lengths. To improve bone cutting efficiency, sagittal saws oscillate at high speeds, but this creates frictional heating that can harm bone cells. The focus of this research was to design a new sagittal sawing device for improved cutting efficiency. It was hypothesized that the addition of an impulsive thrust force during the cutting stroke would increase cutting rates in cortical bone. A cam-driven device was developed and tested in bovine cortical bone. The impulsive thrust force was achieved by creating a component of blade motion perpendicular to the cutting direction, i.e., orbital blade motion. At the start of each cutting stroke, the mechanism drove the saw blade into the surface of the bone, increasing the thrust force with the intention of increasing the depth of cut per tooth. As each cutting stroke was completed, the blade was retracted from the surface for the purpose of clearing bone chips. The design parameters investigated were cutting stroke length, thrust stroke length, and blade oscillation frequency. A three-factor, two-level design of experiments approach was used to simultaneously test for the effect of design parameters and their interactions on volumetric cutting rate ($n=32$). The addition of orbital blade motion to the sagittal saw improved bone cutting rates over traditional oscillatory motion, especially at lower cutting stroke lengths and higher oscillation frequencies ($p < 0.05$). However, the magnitude of orbital blade motion based on thrust stroke length was limited by a threshold value of approximately 0.10 mm that when exceeded caused the sagittal saw to rebound from the surface of the bone causing erratic cutting conditions. The factor with the greatest positive effect on cutting rate was oscillation frequency. Cutting rates in cortical bone can be improved with the proposed orbital action sagittal saw. [DOI: 10.1115/1.4023500]

Keywords: sagittal saw, bone cutting, orthopaedic, orbital sawing, surgical tool

1 Introduction

A sagittal saw is the primary tool used by orthopedic surgeons for resection of bone. Generally, sagittal saws are used in confined spaces where the stroke length of the blade must be minimized to reduce inadvertent cutting of surrounding tissue and to permit precise control of the saw by the surgeon. Sagittal saws are frequently used in total joint replacement of the hip and knee. Rather than reciprocating a saw blade to create linear motion, sagittal saws rotate the blade between 3 deg and 5 deg to create oscillatory motion. A combination of blade length and oscillation angle results in a relatively short stroke length over an arc of approximately 3 mm to 9 mm. To facilitate cutting by multiple teeth over the reduced stroke length, sagittal saw blades used in total joint arthroplasty typically have a tooth pitch of 5 to 7 teeth per cm. The combination of short stroke length and reduced tooth spacing results in relatively inefficient cutting of bone.

One method to improve cutting performance of sagittal saws is to increase the oscillation rate. Sagittal saws typically run at 10,000 to 20,000 oscillations per minute. Unfortunately, the high rate of oscillation causes frictional heating of the surrounding bone [1,2]. High temperatures, over an extended period of time, cause thermal injury to bone. It has been shown that if bone cells are subjected to sustained temperatures above 47°C for longer

than one minute bone formation is reduced [3], and cell necrosis can be caused by temperatures above approximately 56°C [4]. During *in vitro* studies with oscillating and reciprocating bones saws, temperatures exceeded 170°C when cutting bovine cortical bone [5,6]. *In vivo* temperature measurements during 30 human knee arthroplasty operations resulted in a median temperature of 68°C, with a high of 100°C [7]. Damage to the bony bed can cause complications such as infection [8] and aseptic implant loosening of porous implants due to a lack of sufficient bone ingrowth [9,10].

A potential method to reduce temperatures during bone sawing is to modify the saw blade design. Unfortunately, an investigation of several commercial blades and specialty designed tooth forms revealed little change in temperature during sagittal sawing of bovine cortical bone [11]. A more thorough investigation of saw blade thickness, length, width, tooth offset distance, and tooth form geometry revealed that rake angle had the greatest effect on temperature, but the lowest temperatures achieved were still harmful to bone tissue [12]. A modest decrease in temperature has been achieved by sustained irrigation during sawing [13], and by using saw blades with integral irrigation channels, which resulted in temperature reductions below the necrotic level [2]. However, irrigation of saw blades during surgical procedures has not been accepted as standard clinical practice, perhaps due to resistance by surgeons to flush excess debris into the wound site or by the limited distribution and higher cost of specialty blades.

Based on a lack of success in reducing bone cutting temperatures through saw blade design, a new approach is taken here to

¹Corresponding author.

Manuscript received March 26, 2012; final manuscript received December 29, 2012; published online February 13, 2013. Assoc. Editor: Jahangir Rastegar.

focus on improving cutting rates. The research is motivated by the premise that higher cutting rates may result in lower sawing temperatures for two reasons: (1) the blade is in contact with the bone for a shorter period of time, thereby reducing the amount of heat transferred, and (2) because larger bone chips may carry more heat away from the freshly cut surface. It is well known in metal cutting; for example, that chips carry the majority of the heat away from the machined surface [14].

The effort to reduce bone cutting temperatures through improved cutting efficiency requires two separate research initiatives. The first is to develop a new sawing device and to understand which design parameters affect cutting rate, and the second is to measure bone sawing temperatures while cutting with the new device and various saw blades. This paper reports on the first initiative, the design and testing of a new sagittal sawing device to improve bone cutting rates.

2 Design

The basic mechanism to oscillate a sagittal saw blade has not changed for several decades. The primary focus of designers has been on a shift from pneumatic to battery power and on the development of proprietary saw blade geometry. Meanwhile, portable electric tools used in the construction industry for sawing wood and metal have enjoyed significant upgrades related to mechanism design to create various saw blade trajectories.

The addition of orbital blade action to jigsaws and more recently reciprocating saws has improved their cutting efficiency [15]. Orbital blade motion is achieved in these tools by translating the blade perpendicular to the primary reciprocating direction, causing the saw blade to trace a path that resembles an elongated ellipse. The major diameter of the ellipse is aligned with the reciprocating stroke length, while the minor diameter is related to the orbital stroke length.

During orbital blade motion, the saw motor and related mechanism impart a mechanical thrust force to the surface of the cut. The mechanical thrust force is complementary to the static thrust force applied by the tool operator and is timed to occur during the cutting stroke. The blade is then lifted from the workpiece on the return stroke. The mechanical or “dynamic” thrust force component causes the saw blade teeth to penetrate deeper into the surface of the workpiece and thereby improve cutting rates.

2.1 Orbital Mechanism. A new sagittal sawing mechanism was designed to impart a dynamic thrust force perpendicular to the path of blade oscillation. An important design consideration when analyzing cutting and thrust forces in sagittal sawing is that cutting occurs in both the forward and reverse strokes. In jigsaws and reciprocating saws, the cutting force occurs in only one direction. For example, the cutting force from a jigsaw blade draws the base plate of the saw into contact with the surface of the workpiece. In this situation, the balance of forces between the workpiece and base plate prevents the jigsaw from bouncing about erratically. However, in sagittal sawing, the cutting force must be offset by operator control during freehand cutting as the base of the saw cannot be steadied against the bone.

For sagittal saws, cutting in both directions causes a natural force balance due to high oscillation rates and shorter stroke lengths. To maintain this balance of cutting forces with the addition of orbital blade motion, a sagittal saw blade cannot travel in an elliptical path that promotes cutting in only one direction. Rather, the blade must be advanced into the bone for one half of the forward stroke and then retracted during the remaining half of the forward stroke. This motion must then be repeated during the return stroke, resulting in a “figure-eight” path for each tooth rather than an elliptical path (Fig. 1).

Analytically, a figure-eight path is defined by a parametric equation of the following form:

$$R(t) = \langle \sin(t), \cos(2t) \rangle \quad (1)$$

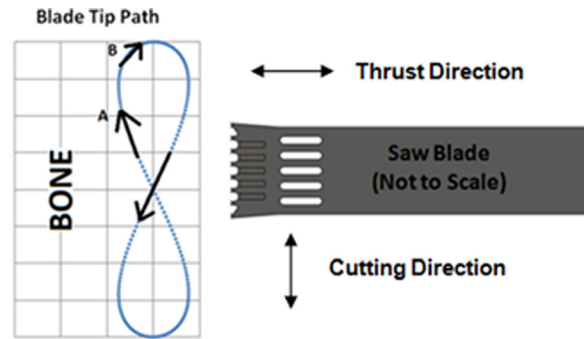

Fig. 1 Figure-eight saw blade motion created by the new sagittal sawing device. From point (a) to point (b), a thrust force is created by a cam mechanism to drive the saw blade teeth deeper into the surface of the bone on each cutting stroke.

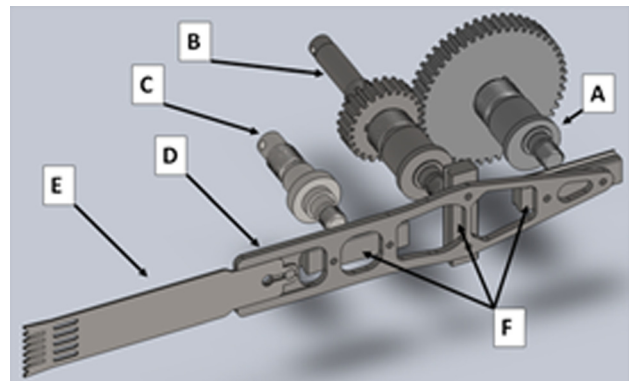

Fig. 2 Major components of the new sagittal sawing device: (a) cutting camshaft, (b) thrust camshaft, (c) pivot shaft, (d) blade carrier, (e) saw blade, and (f) linear bearings

Physically, Eq. (1) describes two oscillations with orthogonal motion, with one being twice the frequency of the other. To mimic this behavior in machine design, a 2:1 gear ratio can be used to create the correct frequency and phase angle. This was accomplished in the new sawing device by using two mechanically coupled shafts with offset cams, (a) and (b) in Fig. 2 (several less prominent components, including the bearings, have been removed for clarity). The camshaft responsible for blade movement in the thrust direction, camshaft (b), rotates at twice the speed as the camshaft responsible for motion in the cutting direction, camshaft (a). The fixed 2:1 gear ratio forces the blade to be extended and retracted during both the forward and reverse cutting strokes, resulting in the desired figure-eight motion of the saw blade teeth.

A pivot shaft (c) and blade carrier (d) were used in combination with three linear bearings (f) to restrict the mechanism degrees of freedom while creating figure-eight blade motion (Fig. 2). The cam offset on the cutting shaft produced a side-to-side motion in the top of the blade carrier. This motion caused the blade carrier to rotate about the pivot shaft, producing a side-to-side motion at the cutting edge of the blade. The cam offset on the thrust shaft produced an up-and-down motion in the blade carrier, driving the blade normal to the surface of the bone. By combining the amplitude and phase of these two cam-generated motions, a wide variety of blade paths can be achieved.

If angle θ is associated with the cutting camshaft and angle β is associated with the thrust camshaft, then Eq. (2) describes the relationship between these two angles, where angle λ is the phase offset.

$$\theta = -\frac{1}{2}\beta + \lambda \quad (2)$$

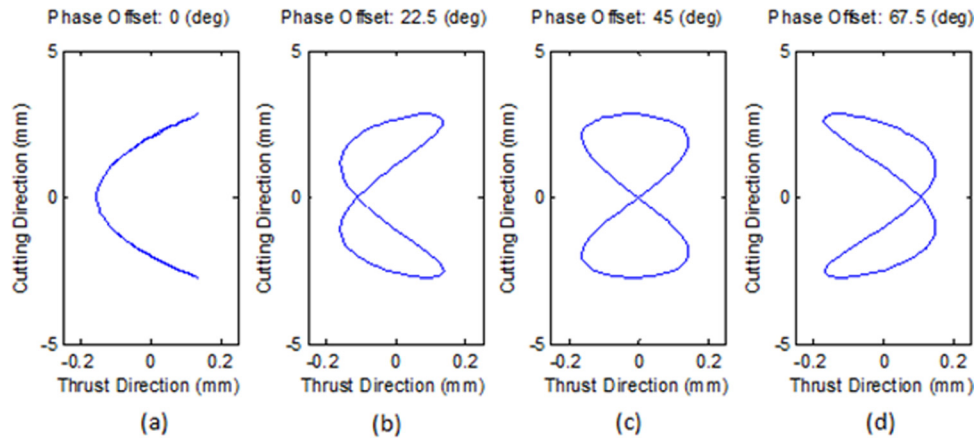

Fig. 3 Variations in cutting path based on phase offset angle between the thrust and cutting camshafts: (a) 0 deg, (b) 22.5 deg, (c) 45 deg, and (d) 67.5 deg

The width and amplitude of the figure-eight blade motion is determined by the magnitude of the cam offsets and the distance between the camshafts and the pivot shaft. By establishing an origin (0,0) of a Cartesian coordinate system at the center of the pivot shaft, the center of the offset cam on the thrust camshaft is defined by

$$P_T = \langle L_B + \varepsilon \cos \beta, \varepsilon \sin \beta \rangle \quad (3)$$

Where L_B is the distance between the thrust camshaft and the pivot shaft and ε is the thrust cam offset. Likewise, the center of the offset cam on the cutting camshaft is defined by

$$P_C = \langle L_A + \delta \cos \theta, \delta \sin \theta \rangle \quad (4)$$

Where L_A is the distance between the cutting camshaft and the pivot shaft and δ is the cutting cam offset. The distance to the center of the offset cams, Eqs. (3) and (4), along with the distance between the pivot shaft and the tips of the saw blade teeth, determine the width and amplitude of the figure-eight motion.

The shape of the figure-eight path is controlled by the phase angle, λ , between the cutting and thrust force camshafts. The figure-eight path is flattened to resemble an arc when the phase angle is 0 deg (Fig. 3(a)), and a mirror image of this arc is produced when the phase angle is 90 deg. For this research, the mechanism was assembled with the phase angle held constant at 67.5 deg, Fig. 3(d), which in preliminary testing produced consistent cutting results and less rebounding due to the shallower angle of attack than for example a phase angle of 45 deg (Fig. 3(c)).

2.2 Test Fixture. The new device was configured for bench-top testing appropriate for an investigation of design parameters. For implementation in a portable surgical tool, the device design could remain unchanged, but the bearing and gearing system would require a reduction in size and a change in configuration depending on motor orientation.

The purpose of the test fixture was to guide the sawing device on a repeatable path under a constant static load. Also, an oversized motor of sufficient stiffness was required to eliminate changes in oscillation frequency during sawing. This permitted oscillation frequency to be studied as an independent factor from thrust force.

The sawing device was attached to an aluminum base plate with bearings used to stabilize the cutting, thrust, and static shafts. A cut-away view (Fig. 4), shows the bearing arrangement used to support the cutting shaft. The thrust shaft was supported in a similar manner. Spur gearing was chosen to couple the cutting and thrust shafts with a 2:1 gear ratio. The outboard side of the thrust shaft was connected in-line with a flexible coupling to a 2.25

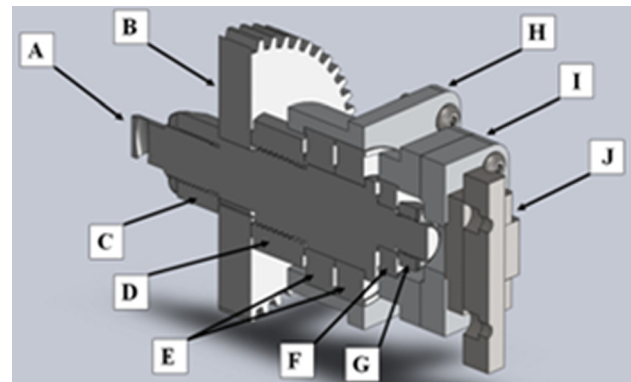

Fig. 4 Camshaft bearing assembly responsible for cutting stroke: (a) camshaft, (b) spur gear, (c) gear retention nut, (d) shaft bearing retention nut, (e) shaft bearings, (f) cam offset bearing, (g) cam bearing retention nut, (h) shaft bearing housing, (i) linear bearing housing, and (j) linear bearing

horsepower router (Porter Cable, Model 892, Jackson, TN). The completed device with drive shaft assemblies is shown in Fig. 5.

The sawing mechanism and motor were mounted to a rigid frame that used a counterbalance mass and adjustable pivot point to achieve precise control of the applied thrust force (Fig. 6). The small rotation angle of the fixture during cutting resulted in a negligible change to thrust force. Finally, the test fixture included a machinist's vice to clamp the bone sample in place during sawing.

3 Materials and Methods

The experimental goal was to determine the effect of design parameters on volumetric cutting rate during cortical bone sawing. The design parameters of interest were frequency of oscillation, amplitude of the cutting stroke length, and amplitude of the thrust stroke length. Using a Design of Experiments (DOE) approach, the design parameters were tested simultaneously. During the DOE, several process parameters were held constant, including applied thrust force, blade geometry, and bone sample geometry.

3.1 Bone Samples and Blade Geometry. Cortical bone samples were taken from the mid-diaphysis region of two femurs from a 20–30 month adult bovine. The femurs were purchased from an approved abattoir (Blood Farm, Groton, MA), processed with a bandsaw, and frozen at -10°C . During machining and subsequent handling, bone samples were kept moist in a physiologic solution (Hank's Balanced Salt Solution, Life Technologies, NY)

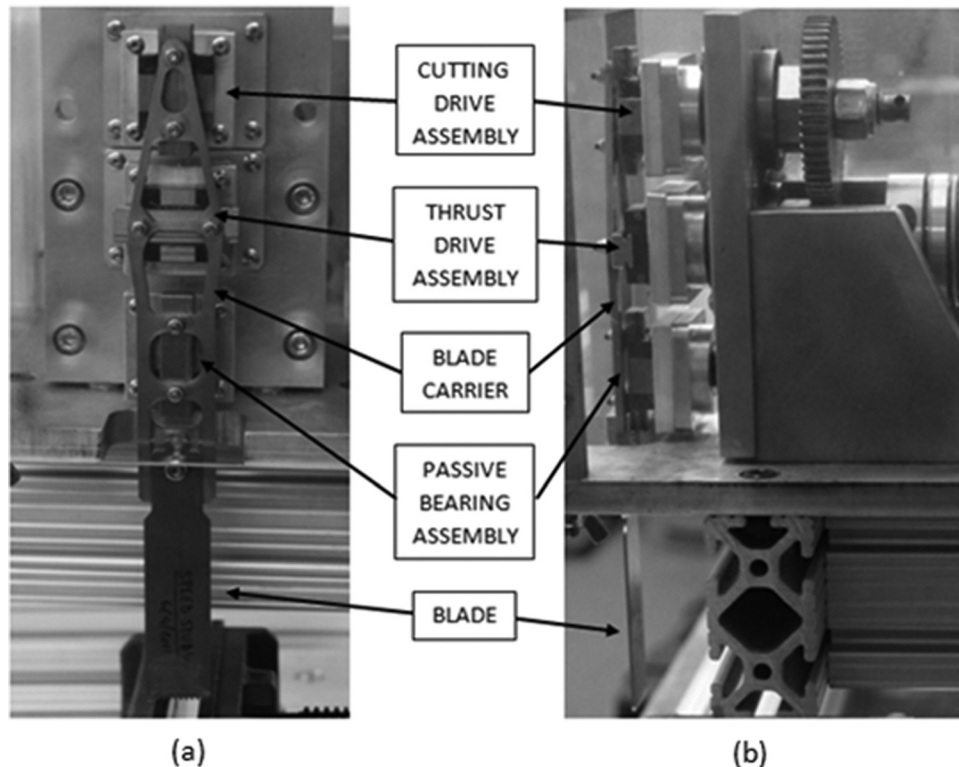

Fig. 5 Sagittal sawing mechanism used in the design of experiments: (a) front view, (b) side view

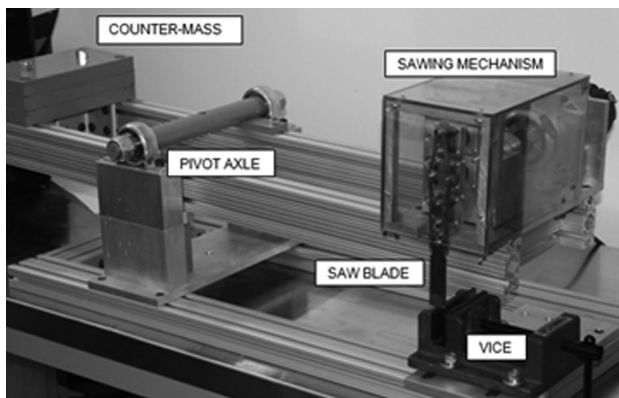

Fig. 6 Test apparatus used to apply a constant thrust force during experiments with the sagittal sawing device

and refrigerated. Bone samples were machined to a uniform cross section, 18 mm wide, 5.7 mm thick, and 75 mm long. The length dimension of all bone samples was parallel to the primary osteon direction.

For each sample, the density and location within the bone was recorded. Nine bone samples were fabricated with an average density of 2.04 g/cm^3 and a standard deviation in density of 0.07 g/cm^3 . From visual inspection, the bone samples were free from apparent defects. All cutting was done transverse to the primary osteon direction.

Several sagittal saw blades of the same type (Stryker 2108-110, Stryker Orthopaedics, Kalamazoo, MI) were used for screening studies and the DOE. Blades were 24.8 mm wide, 86.7 mm long, and were manufactured from 1.22 mm thick stainless steel. The saw blade teeth did not lie along a straight line, but rather followed an arc with a radius of 86.7 mm. Teeth were symmetric with a -30 deg rake angle and spaced 2.12 mm apart with a lateral

set of 0.12 mm. Considering the 18 mm sample width and 2.12 mm tooth spacing, approximately eight teeth were in contact with the workpiece at any given time. Several blades were used in a random rotation to negate the effect of cutting edge wear and to prevent the influence of slight changes in blade geometry on cutting rates. Blade wear, monitored by microscopic inspection, was negligible for the number of cuts conducted.

3.2 Cutting Time and Oscillation Frequency. The time to make each cut was determined from load readings taken from a quartz 3-component dynamometer (9257B, Kistler Instruments, Switzerland) that was positioned beneath the vice. The thrust force component of the data was filtered using a 4th order low-pass Butterworth Filter with a cut-off frequency of 10 Hz and then plotted (Fig. 7). The start time of the cut was selected to be the moment at which the thrust force exceeded a small threshold value ($<0.1 \text{ N}$), which corresponded to the saw hitting the surface of the bone. The end time for the cut was set to be the last time at which the thrust force dropped below the nominal cutting value, which corresponded to the blade breaking through the bone. Cutting time, along with slot thickness (kerf) and sample cross section were used to determine volumetric cutting rate.

Speed of the router motor was controlled with a 120 V, 15 Amp variable transformer (Model SPN1510B, Staco Energy Products Co., Dayton, OH). Oscillation frequency of the device was measured using the cutting force component from the dynamometer data. Cutting force data was filtered using a 4th order band-pass Butterworth Filter with the lower cutoff frequency at 10 Hz and the upper cut-off frequency at five times the commanded cutting frequency. A discrete Fourier Transform was then used to generate a plot of the amplitude of each frequency component of the signal, with the largest peak corresponding to the cutting frequency of the saw.

3.3 Screening Studies. Screening studies were conducted to facilitate the DOE by determining an appropriate range and level

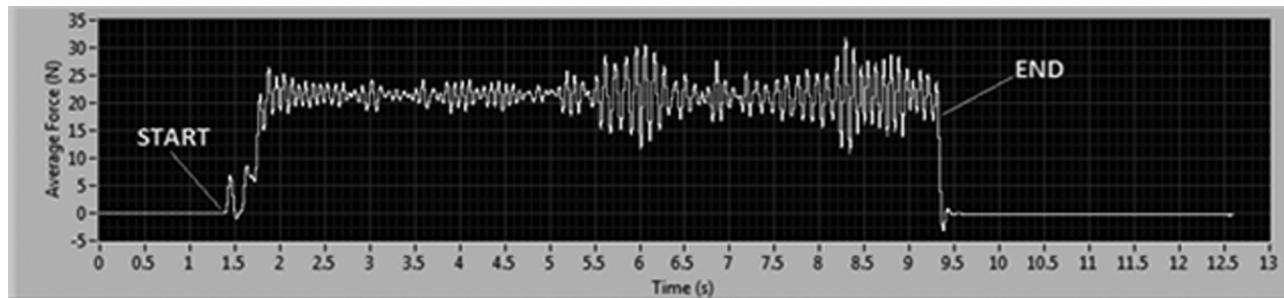

Fig. 7 Thrust force plot from the dynamometer showing the start and end times for one cut, which were used to determine volumetric cutting rate

for each of the design parameters (factors). The first study conducted was to determine the effect of oscillation frequency on cutting rate. The applied force was held constant at 22.2 N for two stroke lengths, 2.88 mm and 7.13 mm. The applied thrust force was chosen to represent the pressure typically applied by an orthopedic surgeon. The thrust force was set using a portable force gauge (MG20, Mark 10 Co., Copiague, NY) with an accuracy of ± 0.4 N. Thrust force was measured at the tip of a saw blade tooth, in the middle of the saw blade. Variation of the applied thrust force, due to slight rotation of the fixture during sawing, was determined to be less than 0.2 N and was therefore neglected. For cutting frequencies between 122 Hz and 154 Hz, the volumetric cutting rate was determined to be approximately linear for both stroke lengths. From these results, it was determined that cutting frequency and stroke length could be represented by two-level factors in the DOE.

A second screening study was conducted to determine the effect of thrust stroke length on volumetric cutting rate. Thrust force was held constant at 22.2 N and cutting frequency was held constant at 122 Hz. For thrust stroke lengths above 0.20 mm, it was difficult for the blade to settle into a kerf on the surface of the workpiece. The higher thrust stroke amplitudes caused the device to bounce off the surface of the bone. From these experiments, it was determined to use a maximum thrust stroke length of 0.10 mm in the DOE.

3.4 Design of Experiments. A three-factor, two-level, full-factorial DOE was conducted. Volumetric cutting rate was the single response variable of interest. The three factors and corresponding levels (low, high) investigated were: (1) Oscillation frequency (122 Hz, 154 Hz), (2) Cutting stroke length (2.88 mm, 7.13 mm), and (3) Thrust stroke length (0.00 mm, 0.10 mm). The levels chosen were within the ranges investigated in the screening studies. The lower limit of thrust stroke length generated nearly oscillatory motion, comparable to contemporary sagittal saws.

For each of the eight treatments (low/high factor combinations), the experiment was replicated four times ($n = 32$). For each trial, the bone samples were removed from the refrigerated solution, chosen at random from a group of nine potential samples, and clamped in the vice for sawing. Appropriate cam shafts were chosen to generate the cutting and thrust stroke amplitudes and the oscillation frequency was set using the variac. Applied thrust force was held constant at 22.2 N for all experiments.

4 Results

The aim of the experiments was to determine the cutting effectiveness of adding figure-eight orbital blade motion to a sagittal bone sawing device. Using this device and a DOE approach, bone sawing rates were determined as a function of three design parameters. The results indicate that cutting rate was affected positively by an increase in cutting stroke length, thrust stroke length, and oscillation frequency (Fig. 8). The shaded bars signify pure oscillatory motion, i.e., the thrust stroke length was zero for these

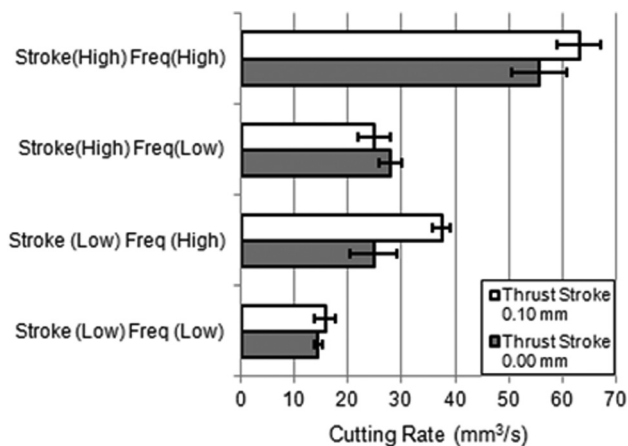

Fig. 8 Results from the three-factor, two-level design of experiments showing the effect of design parameters on cutting rate. Cutting stroke length: (high) = 7.13 mm and (low) = 2.88 mm; oscillation frequency (high) = 154 Hz and (low) = 122 Hz.

experiments. The error bars indicate plus and minus one standard deviation from the mean cutting rate.

The highest cutting rate, 63.2 mm³/s, was achieved at high oscillation frequency, high cutting stroke length, and a figure-eight orbital blade path with a thrust stroke length of 0.10 mm. This cutting rate was approximately 13% greater than pure oscillatory motion under the same oscillation frequency and cutting stroke length. Alternatively, the lowest cutting rate, 14.4 mm³/s, occurred at the low oscillation frequency and the low cutting stroke length for pure oscillatory motion. This fourfold difference from the lowest to the highest cutting rate is indicative of how mechanism design parameters can affect sawing efficiency.

The cutting rate data was analyzed for each treatment to determine the main and interaction effects. Main effects were determined by taking the difference in the average response between the high and low levels of the design parameters. Afterward, the main effects were normalized according to the most significant effect, which in this case was oscillation frequency (Fig. 9). The second most significant main effect was cutting stroke length, followed by thrust stroke length. With regard to the two-factor interaction between cutting stroke length and thrust stroke length, a negative effect implies a reduction in cutting rate. The remaining two-factor interactions were significant, primarily due to the strength of the cutting frequency effect. The three-factor interaction was negligible.

A hypothesis test was conducted to determine the statistical significance of the experimental observations. The mean cutting rates and corresponding P-values (t-test with degrees of freedom = 24) are shown in Table 1. For P-values less than 5%, the mean results were considered to be real (not due to random variation) and statistically significant. In the first two treatments, each with a low

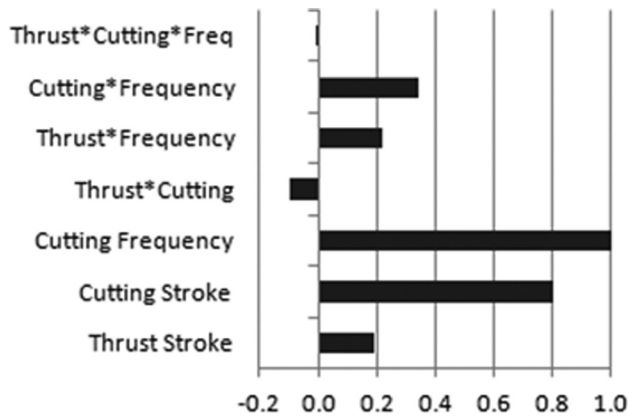

Fig. 9 Normalized effect of main factors and their interactions on volumetric cutting rate. Thrust = thrust stroke length; cutting = cutting stroke length; freq = oscillation (cutting) frequency.

cutting stroke length, the effect of orbital blade motion to improve cutting rates is considered real and significant ($P=0.038$ and $P=0.010$). For both treatments at higher cutting stroke lengths, the addition of orbital blade motion was not statistically significant ($P > 0.050$).

5 Discussion

The motivation behind the design of a new sagittal sawing device was to improve bone cutting efficiency. This was accomplished by adding orbital blade motion to create a dynamic thrust force component in addition to the force applied by the surgeon. Unlike jigsaws and reciprocating saws that cut in only one direction, a sagittal saw cuts in two directions, which mandated an orbital blade path that resembled a figure-eight rather than an ellipse.

The results indicate that cutting rates can be improved by modifying the sagittal sawing mechanism to produce a dynamic thrust force. On a percentage basis, improvements to cutting rates were more pronounced when orbital action was used in combination with a shorter cutting stroke length. At lower cutting stroke lengths; for example 2.88 mm, the distance each tooth traverses the surface of the bone is severely limited. Under these conditions, the addition of a dynamic thrust force likely causes the saw blade teeth to be further imbedded into the bone, creating greater depths of cut for each oscillation of the blade. The same scenario is likely during longer cutting stroke lengths, but the effect is lessened in comparison to the amount of chips being created due to each tooth traversing more of the surface. In general, this result indicates that it may be possible to create a sagittal saw with orbital blade motion that cuts at the same rate as a contemporary saw, but has a shorter stroke length. Less blade motion is always desirable because it gives the surgeon greater control of the saw and prevents the likelihood of damage to surrounding tissue as the blade exits the intended cut. Alternatively, orbital blade motion could be used at a lower oscillation frequency to achieve the same cutting

rate as contemporary saws, and the reduced speed may contribute to reducing bone sawing temperatures.

Results from the screening experiment on thrust stroke length revealed that the magnitude of orbital motion is limited. There is an upper threshold and when exceeded it causes the saw to jump about erratically rather than settling into a kerf. For the mechanism design and process parameters considered, the upper threshold of thrust stroke length appeared to be approximately 0.10 mm. It is likely that a more aggressive stroke length creates a dynamic thrust force sufficient to accelerate the tool upwards such that the timing is disrupted between the application of the thrust force and the cutting stroke. The disruption of timing occurs when the rebounding force of the blade off the workpiece surface is greater than the applied thrust force. At this point, there was a significant reduction in cutting rate observed and the kerf width became enlarged as the blade moved laterally in addition to oscillating.

The proper orbital stroke length to initiate more aggressive cutting while preventing tool rebound depends on the cutting mechanics of the workpiece. Intuitively, a softer workpiece would be more forgiving to greater thrust force amplitude as the teeth would imbed themselves further into the surface. For example, it is common to reduce the magnitude of thrust stroke length when using an orbital action reciprocating saw for metal cutting applications, as opposed to cutting wood. Thrust stroke length reduction is done not only because the tool begins to bounce off the surface of the workpiece, but also because the cutting edges of the saw blade teeth begin to chip as a result of dynamic thrust loads exceeding the fracture strength of the hardened tooth. In order to optimize the degree of thrust stroke length, in relation to the cutting stroke length, a better understanding of bone chip creation during sawing is necessary. An analysis of bone machining may provide some insight into the mechanics that govern the sagittal sawing process under a dynamic thrust force.

The mechanics of bone cutting and chip creation has been studied with a particular emphasis on orthogonal machining. In general, these studies have shown that the classic Merchant equations for metal cutting are not applicable to bone cutting due to the anisotropic and inhomogeneous structure of bone [16,17]. In addition, orthogonal cutting studies in bone have revealed a strong relationship between cutting forces and depth of cut. Wiggins and Malkin conducted orthogonal tests under various cutting conditions, rake angles, and depths of cut in order to minimize cutting forces [18]. They observed an increase in specific cutting energy at lower depths of cut. They also compared cutting results from bovine and human bone, concluding that the mechanics of chip formation were similar. Chip formation was observed to occur through a series of discrete fractures. Malak and Anderson investigated the orthogonal cutting of cancellous bone where it was observed that the specific cutting energy increased in a nonlinear manner as the depth of cut was decreased [19].

The relationship between specific cutting energy and depth of cut in the orthogonal machining studies is important because low depths of cut are common to bone sawing. During sagittal sawing over a range of operating parameters, the average depth of cut per tooth was determined to be less than $8 \mu\text{m}$, which is typically less than the cutting edge radius of a saw blade tooth [20]. Based on

Table 1 Effect of orbital blade motion on mean cutting rate

Oscillation frequency (Hz)	Cutting stroke (mm)	Volumetric cutting rate (mm^3/s)			P value
		No orbit (0.00 mm stroke)	Orbit (0.10 mm stroke)	Percent difference	
122	2.88	14.4	15.7	9.0%	0.038
154	2.88	24.9	37.5	50.6%	0.010
122	7.13	27.8	24.9	-10.4%	0.069
154	7.13	55.7	63.2	13.5%	0.061

the previous studies of orthogonal bone machining and the low depths of cut per tooth encountered in sagittal sawing, the specific cutting energy during bone sawing is expected to be quite high. Therefore, it is likely that a significant thrust force will be required to cause a saw blade tooth to plunge into the surface of the bone, rather than simply riding along the top and causing frictional heating. This implies there is a tight window of operation where a sufficient dynamic thrust force is required to initiate bone chipping, but not so aggressive as to promote rebounding of the blade from the workpiece. With the low depths of cut experienced in sawing, the inhomogeneous microstructure of bone is of some interest as it will likely affect the ability of a tooth to penetrate the surface.

The microstructure of bone is more analogous to wood than metal, with cortical bone osteons aligned parallel to the axis of a long bone just as wood fibers are aligned parallel to the axis of a tree trunk. The orientation of osteons has an effect on bone cutting rates and forces [1] not unlike that experienced when ripping or crosscutting wood. Osteons in cortical bone are approximately 50 μm to 400 μm in diameter [21], which is approximately an order of magnitude larger than the depths of cut per tooth experienced in sagittal sawing. Therefore, knowledge of factors that influence chip creation when cutting osteons is essential to understanding sawing of cortical bones.

A DOE approach was pursued by Yeager et al. to study the effect of bone orientation on cutting forces at various depths of cut [22]. It was concluded that sample orientation, relative to the primary osteon direction, and depth of cut were statistically significant factors influencing cutting forces. Using an electron microscope to examine the surface of freshly cut bone, the authors observed severe deformation, described as "crushed," when cutting with negative rake angle tools. They concluded that under these circumstances, bone debris was formed through the fracture of osteons. Since saw blade teeth normally have negative rake angles, i.e., the teeth are symmetrical and designed to cut in both directions, saw blade teeth may facilitate osteon cracking during cutting.

Sugita and Mitsuishi observed cracks forming along osteon boundaries while viewing transverse cutting of bovine cortical bone under high magnification [23]. From their microscopic observations of bone fracturing, they proposed a machining method whereby the cutting edge is forced into the surface of the bone and then concurrently advanced and lifted to create chips due to fracturing between and across osteons. The cutting motion proposed by Sugita and Mitsuishi is similar to that produced by the new sagittal sawing device with figure-eight orbital blade motion.

Correlation between the shape of the figure-eight blade path and the temperature in the surrounding bone is fertile ground for additional research. While the cutting rate of cortical bone with an orbital blade trajectory was shown to be greater than the cutting rate with traditional oscillatory blade motion, this does not immediately support the conjecture that greater cutting rates produce lower cutting temperatures. The creation of larger chips may carry more heat away from the cutting zone as hypothesized, but there is also more work being done by the blade in the cutting zone and this could produce additional heating.

Acknowledgment

There are no conflicts of interest to report for this research. Funding was provided internally by Tufts University, School of Engineering, Medford, MA. The authors would like to acknowledge Dr. Eric Smith, Chief of Arthroplasty, Department of Orthopedics, Tufts Medical Center, Boston, MA, for being an advisor on this research.

References

- [1] Krause, W. R., 1976, "Mechanical Effects of Orthogonal Bone Cutting," Ph.D. thesis, Clemson University, Clemson, SC.
- [2] Toksvig-Larsen, S., Ryd, L., and Lindstrand, A., 1991, "On the Problem of Heat Generation in Bone Cutting: Studies on the Effects of Liquid Cooling," *J. Bone Joint Surg., Br. Vol.*, **73-B**, pp. 13–15.
- [3] Eriksson, A. R., and Albrektsson, T., 1983, "Temperature Threshold Levels for Heat-Induced Bone Tissue Injury: A Vital-Microscopic Study in the Rabbit," *J. Prosthet. Dent.*, **50**(1), pp. 101–107.
- [4] Matthews, L. S., and Hirsch, C., 1972, "Temperatures Measured in Human Cortical Bone When Drilling," *J. Bone Joint Surg. Am. Vol.*, **54**, pp. 297–308.
- [5] Wachter, R., and Stoll, P., 1991, "Increase of Temperature During Osteotomy: *In Vitro* and *In Vivo* Investigations," *Int. J. Oral Maxillofac. Surg.*, **20**(4), pp. 245–249.
- [6] Krause, W. R., Bradbury, D. W., Kelly, J. E., and Lunceford, E. M., 1982, "Temperature Elevations in Orthopaedic Cutting Operations," *J. Biomech.*, **15**(4), pp. 267–275.
- [7] Toksvig-Larsen, S., and Ryd, L., 1989, "Temperature Elevation During Knee Arthroplasty," *Acta Orthop. Scand.*, **60**(4), pp. 439–442.
- [8] Christie, J., 1981, "Surgical Heat Injury to Bone," *Injury*, **13**, pp. 188–190.
- [9] Haddad, R. J., Cook, S. D., and Thomas, K. A., 1987, "Biological Fixation of Porous-Coated Implants," *J. Bone Joint Surg. Am. Vol.*, **69**(9), pp. 1459–1466.
- [10] Ryd, L., Lindstrand, A., Stenstrom, A., and Selvik, G., 1990, "Porous Coated Anatomic Tricompartamental Tibial Component Fixation: Relation Between Prosthetic Position and Micromotion," *Clin. Orthop.*, **251**, pp. 189–197.
- [11] Toksvig-Larsen, S., Ryd, L., and Lindstrand, A., 1992, "Temperature Influence in Different Orthopaedic Saw Blades," *J. Arthroplasty*, **7**(1), pp. 21–24.
- [12] Ark, T. W., Thacker, J. G., McGregor, W., Rodeheaver, T., and Edlich, R. F., 1977, "Innovations in Oscillating Bone Saw Blades," *J. Long-Term Eff. Med.*, **7**, pp. 279–286.
- [13] Ark, T. W., Neal, J. G., Thacker, J. G., and Edlich, R. F., 1998, "Influence of Irrigation Solutions on Oscillating Bone Saw Blade Performance," *J. Biomed. Mater. Res.*, **43**(2), pp. 108–112.
- [14] Trent, E. M., and Wright, P. K., 2000, *Metal Cutting*, 4th ed., Butterworth-Heinemann, Burlington, MA, Chap. 5.
- [15] Bednar, T. R., Neitzell, R. D., and Steele, M. S., 2001, "Orbital Reciprocating Saw," U.S. Patent No. 6,249,979.
- [16] Jacobs, C. H., Pope, M. H., Berry, J. T., and Hoaglund, F., 1974, "A Study of the Bone Machining Process—Orthogonal Cutting," *J. Biomech.*, **7**(2), pp. 131–136.
- [17] Alam, K., Mitrofanov, A. V., and Silberschmidt, V. V., 2009, "Finite Element Analysis of Forces of Plane Cutting Cortical Bone," *Comput. Mater. Sci.*, **46**(3), pp. 738–743.
- [18] Wiggins, K. L., and Malkin, S., 1978, "Orthogonal Machining of Bone," *J. Biomech. Eng.*, **100**, pp. 122–130.
- [19] Malak, S., and Anderson, I., 2008, "Orthogonal Cutting of Cancellous Bone With Application to the Harvesting of Bone Autograft," *Med. Eng. Phys.*, **30**, pp. 717–724.
- [20] Kelly, M. P., 2011, "Sagittal Bone Saw With Orbital Blade Action," senior thesis, Tufts University, Medford, MA.
- [21] Reilly, D. T., and Burstein, A. H., 1974, "The Mechanical Properties of Cortical Bone," *J. Bone Jt. Surg., Am. Vol.*, **56**, pp. 1001–1022.
- [22] Yeager, C., Nazari, A., and Arola, D., 2008, "Machining of Cortical Bone: Surface Texture, Surface Integrity and Cutting Forces," *Mach. Sci. Technol.*, **12**, pp. 100–118.
- [23] Sugita, N., and Mitsuishi, M., 2009, "Specification for Machining the Bovine Cortical Bone in Relation to its Microstructure," *J. Biomech.*, **42**, pp. 2826–2829.